

DATA SHEET

PRESSURE SENSITIVE REGULATING UNLOADER



Models: 7693, 7694



Model 7693 Shown

FEATURES

- Provides system pressure setting and protection for single gun (non-weep) and pump installation.
- Compact size with optional ports for easy installation.
- Pressure sensitive feature permits wide range of flows and immediate pressure when gun opens.
- Color coded spring for easy identification and simple change from one model to another.
- Standard NBR o-rings with alternative options for temperature and chemical compatibility.
 - FPM – .0110 (7693.0110, 7694.0110)

COMMON SPECIFICATIONS

	U.S.	Metric
Maximum Operating Temperatures		
Standard Buna O-Rings	140° F	60° C
Std. Buna O-rings (Intermittent)	195° F	90° C
Optional FPM O-rings	240° F	115° C
Inlet Ports (2)	3/8" NPT(F)	3/8" NPT(F)
Discharge Port (1)	3/8" NPT(F)	3/8" NPT(F)
By-Pass Ports (2)	3/8" NPT(F)	3/8" NPT(F)

For Relief Valve version add .100 to unloader model number.

SPECIFICATIONS

	U.S. Measure	Metric Measure
7693		
Flow Range	2.5-10.5 gpm	9.5-40 lpm
Pressure Range	230-2300 psi	16-160 bar
Weight	1.56 lbs.	0.71 kg
Dimensions	7.51 x 3.25 x 1.97"	190.7 x 82.5 x 50.0 mm
7694		
Flow Range	2.5-10.5 gpm	9.5-40 lpm
Pressure Range	400-4050 psi	28-280 bar
Weight	1.63 lbs.	0.74 kg
Dimensions	7.51 x 3.25 x 1.97"	190.7 x 82.5 x 50.0 mm

Read all CAUTIONS and WARNINGS before commencing service or operation of any high-pressure system.

SELECTION

These pressure sensitive regulating unloaders are designed for systems with single or multiple pumps, solenoid (gate) valves, nozzles, standard or "weep" guns.

These pressure sensitive regulating unloaders should meet both the desired system flow (combined nozzle flow rate requirement) and the designed system pressure.

Notice: Operation below the minimum flow of the unloader causes the unloader to cycle. Operation above the maximum flows of the unloader causes premature unloader wear, cycling and prevents attaining desired system pressure.

INSTALLATION

These unloaders operate properly when mounted in any direction, however, it is preferred to keep the plumbing to a minimum and the adjusting handle easily accessible. The best mounting location is directly on the pump discharge manifold head.

The inlet connections on this unloader are 3/8" NPT(F) ports and are located on the left side and bottom. Arrows and the word "IN" are cast into the body indicating the direction of flow. A new unloader will have a plug in the bottom port, but this plug can be switched to the left side port if needed. Liquid from the discharge of the manifold goes through these connections.

The discharge connection on this unloader is a 3/8" NPT(F) port and is located on the front side (hex end). An arrow and the word "OUT" is cast into the body indicating the direction of flow. Plumbing to the spray guns, solenoid (gate) valves or nozzles are connected here.

The by-pass connections on this unloader are 3/8" NPT(F) ports and are located on the back side and front face. The word "BY PASS" is cast into the body indicating the direction of flow. By-pass liquid is directed out of this port and can be routed to a reservoir (preferred method), or to a drain or to the pump inlet.

OPERATION

These pressure sensitive regulating unloaders hold established system pressure in the discharge line when the trigger gun is closed or solenoid (gate) valve is closed or the nozzle is clogged, thus by-passing all unrequired flow. Squeezing the trigger gun or opening the solenoid (gate) valve will close the by-pass and return to established system pressure.

PRESSURE ADJUSTMENT

1. Setting and adjusting the unloader pressure must be done with the system "on".
 2. Start the system with unloader backed off to the lowest pressure setting (counterclockwise direction).
 3. Squeeze the trigger and read the pressure on the gauge at the pump.
- Note:** Do not read the pressure at the gun or nozzle.
4. If more pressure is desired, release the trigger, turn adjusting handle one quarter turn in clockwise direction.
 5. Squeeze the trigger and read the pressure.
 6. Repeat this process until desired system pressure is attained.
 7. Once the desired system pressure is reached, stop turning the adjusting handle.

Note: Pressure is not set at the factory.

Notice: A minimum by-pass flow of 5% of the unloader rated flow capacity is required for proper unloader performance. If the entire output is directed through the nozzle (zero by-pass) the "cushioning" feature of the by-pass liquid is eliminated and the unloader can wear or malfunction prematurely.

8. If desired system pressure cannot be reached, review TROUBLESHOOTING chart.
9. When servicing existing systems, follow adjustment procedures as stated above.

Note: Do not adjust unloader pressure setting to compensate for a worn nozzle. Check the nozzle as part of the regular maintenance and replace if worn.

Note: A secondary pressure safety relief device (i.e. pop-off valve, safety valve) should be used along with this pressure sensitive regulating unloader. Final adjustment for the relief valve should relieve at 200 psi above the system operating pressure.

Note: By removing the check valve and spring, these unloaders can function as a secondary relief valve.

TYPICAL UNLOADER INSTALLATION

1. Pressure Gauge
2. Pop-off Valve (secondary safety relief valve)
3. Pressure Sensitive Regulating Unloader
4. Triplex Plunger Pump

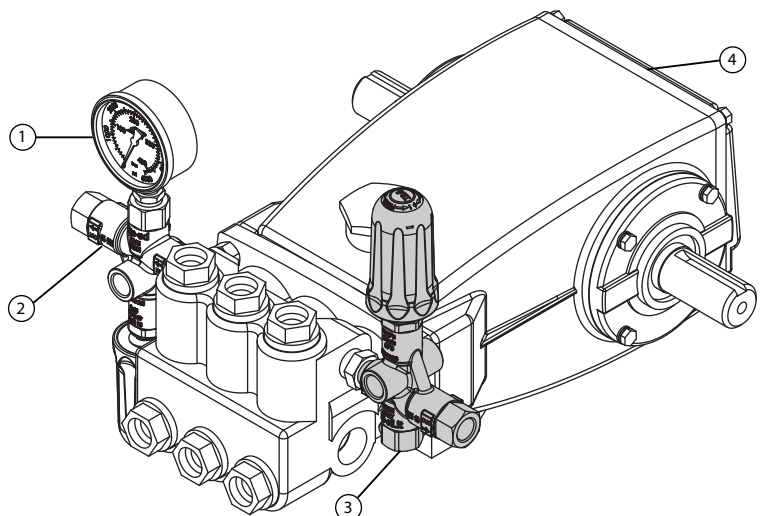

Read all CAUTIONS and WARNINGS before commencing service or operation of any high-pressure system.

DISASSEMBLY

1. Disconnect by-pass, discharge and inlet plumbing from unloader.
2. Remove unloader from pump.
3. Secure body of unloader in a vise with adjusting handle facing up.
4. Remove discharge fitting and o-ring, spring, check valve and o-ring.
5. Examine check valve and discharge fitting for wear, spring for wear or fatigue and o-rings for cuts or wear and replace as needed with check valve kit.

Note: While the discharge fitting is removed, inspect sealing area where the check valve makes contact within the internal body of the unloader for grooves, pitting and wear. If damage is found, stop the repair and replace with complete new unloader. If not, proceed with disassembly.

6. Remove black nylon cap on top of adjusting handle.
7. Unscrew and remove hex nylock nut.
8. Unscrew and remove adjusting handle, flat washer and spring.
9. Examine all parts for scale build up or wear and replace as needed. Examine spring for fatigue or wear and replace as needed.
10. Unscrew and remove two jam nuts from piston stem.
11. Unscrew piston retainer from body of unloader.
12. Grasp threaded end of piston stem and pull from body of unloader. Piston retainer and all associated o-rings should come out upon removal.
13. Remove piston retainer, o-rings and back-up-rings. Examine piston retainer for wear. Examine o-rings and back-up-rings for cuts or wear and replace as needed.
14. Examine piston stem for wear. Examine o-ring and back-up-rings for cuts or wear and replace as needed.
15. Remove bottom inlet fitting and o-ring, spring, ball and seat w/o-ring from bottom inlet connection. Examine seat for grooves and o-ring for cuts or wear and replace as needed.

REASSEMBLY

1. At bottom inlet port, lubricate and install o-ring on outside diameter of seat and press seat squarely into position in the body.
Note: Polished chamfer towards the ball.
2. Install ball and then spring, thread in inlet fitting with o-ring.
3. Lubricate and install o-ring and then backup ring onto threaded end of piston stem.
4. Install backup-ring, o-ring and then backup-ring on opposite end of threaded piston stem. Lubricate all parts.
5. Grasp threaded end of piston stem and press by hand into unloader body.
6. Lubricate and install larger o-ring over threads of piston retainer body. Slide piston retainer with threads facing downwards over piston stem and thread into body.
7. Apply Loctite® 242® to the last few threads of the piston stem. Hand thread two jam nuts to bottom threads of piston stem.
8. Slide spring over piston stem. Install flat washer on top of spring.
9. Thread adjusting handle onto piston stem.
10. Install hex nylock nut onto piston stem.
11. At discharge side of unloader, lubricate and install o-ring onto check valve. Place spring inside check valve. Insert check valve with o-ring and spring into discharge port of unloader body.
12. Lubricate and install o-ring onto threaded end of discharge fitting. Thread in discharge fitting to discharge port of unloader body and tighten with wrench.
13. Remove unloader from vise.
14. Re-install unloader onto pump.
15. Reconnect by-pass, discharge and inlet plumbing to unloader.
16. Proceed to PRESSURE ADJUSTMENT.

Loctite® and 242® are registered trademarks of the Henkel Corporation.

TROUBLESHOOTING

Unloader cycles	<ul style="list-style-type: none"> • Worn O-ring or check valve • Fitting leaking downstream • O-ring in gun worn
Liquid leaking from bottom	<ul style="list-style-type: none"> • O-ring for seat or inlet fitting cut or worn
Liquid leaking from middle	<ul style="list-style-type: none"> • O-ring for piston worn or cut
Unloader will not come up to pressure	<ul style="list-style-type: none"> • Not properly sized for system pressure • Foreign material in unloader • Piston o-rings worn • Nozzle worn or too large • Jam nuts not properly set
Extreme pressure spikes	<ul style="list-style-type: none"> • Adjusting handle turned completely into unloader • Restricted by-pass or no by-pass • System flow exceeds unloader rating

PRESSURE READING

Approximate Pressure Reading at Gauge	Gauge Between Pump/Unloader	Gauge Between Unloader/Gun-Nozzle-Valve
System in Operation (Gun Open)	System Pressure	System Pressure
System in By-Pass (all guns, valves closed)	Low Pressure 0 - 150 psi	System Pressure +200 psi

PARTS LIST

ITEM	PN	MATL	DESCRIPTION	QTY
397	33633	STZP	Washer, Flat	1
398	32116	BB	Nut, Jam (M8)	2
401	—	STZP	Nut, Hex Lock	1
403	31766	NY	Handle, Cap	1
408	32090	STL	Spring, Pressure (White) 7693	1
	32092	STL	Spring, Pressure (Blue) 7694	1
412	39727	S	Stem, Piston	1
414	—	PTFE	Backup-Ring, Piston Stem	1
415	—	NBR	O-Ring, Piston Stem	1
	—	FPM	O-Ring, Piston Stem	1
425	76747	S	Retainer, Piston	1
428	—	NBR	O-Ring, Piston Retainer	1
	—	FPM	O-Ring, Piston Retainer	1
429	—	NBR	O-Ring, Piston Stem	1
	—	FPM	O-Ring, Piston Stem	1
430	—	PTFE	Backup-Ring, Piston Stem	2
434	32325	S	Spring	1
436	76743	—	Seat, Ball Assembly	1
440	—	BB	Housing	1
441	—	NBR	O-Ring, Check Valve	1
	—	FPM	O-Ring, Check Valve	1
442	—	NBR	O-Ring, By-Pass Fitting	1
	—	FPM	O-Ring, By-Pass Fitting	1
443	76736	BB	Valve, Check	1
444	33843	S	Spring, Check Valve	1
446	—	NBR	O-Ring, Discharge Fitting	1
	—	FPM	O-Ring, Discharge Fitting	1
455	76752	BB	Fitting, Inlet 3/8" NPT(F)	1
460	76753	BB	Fitting, Discharge 3/8" NPT(F)	1
462	—	BB	Plug	2
468	76787*	NBR	Kit, O-Ring (Includes 414, 415, 428, 429, 430, 441, 442, 446) After week #4, 2015 (7693); week #12, 2015 (7694)	1
	76760*	FPM	Kit, O-ring (Includes 414, 415, 428, 429, 430, 441, 442, 446) After week #4, 2015 (7693); week #12, 2015 (7694)	1
470	39697*	NBR	Kit, Repair (Includes 414, 415, 428, 429, 430, 436, 441, 442, 446) After week 4/2015 (7693); week #12, 2015 (7694)	1

*See Tech Bulletin #119 for changes prior to week 4/2015 and week 12/2015.

EXPLODED VIEW

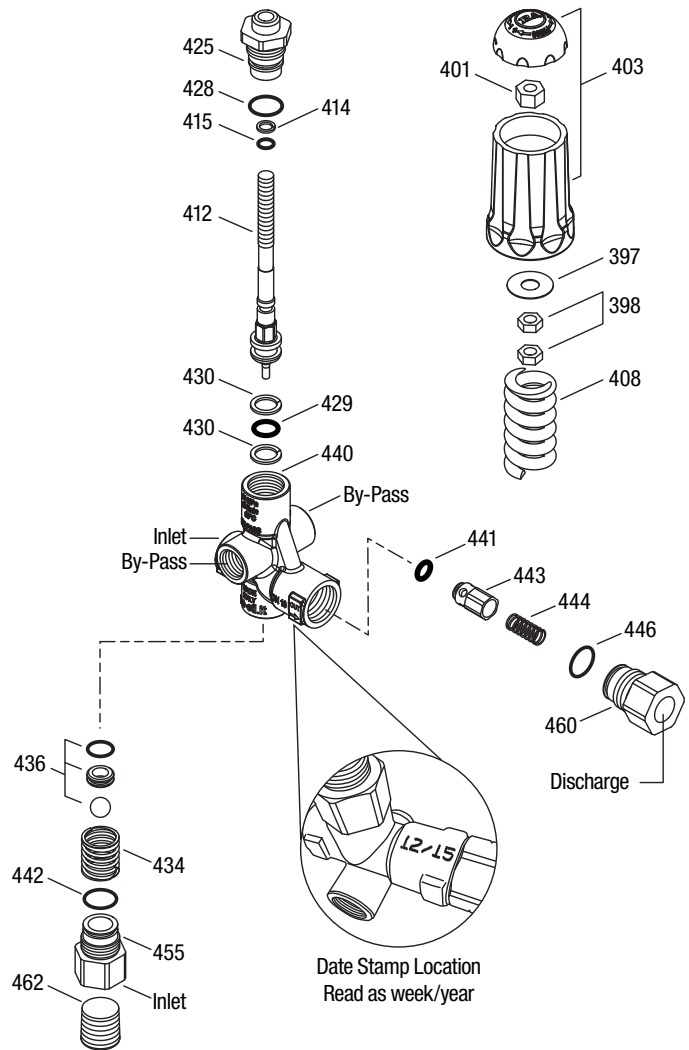

Bold print part numbers are unique to a particular model.

Italics are optional items.

MATERIAL CODES (Not Part of Part Number): BB=Brass FPM=Fluorocarbon
NBR=Medium Nitrile (Buna-N) NY=Nylon PTFE=Pure Polytetrafluoroethylene
S=304SS STL=Steel STZP=Steel/Zinc Plated

⚠ CAUTIONS AND WARNINGS

All High Pressure Systems require a primary pressure regulating device (i.e. regulator, unloader) and a secondary pressure relief device (i.e. pop-off valve, relief valve). Failure to install such relief devices could result in personal injury or damage to pump or property. Cat Pumps does not assume any liability or responsibility for the operation of a customer's high pressure system.

Read all CAUTIONS and WARNINGS before commencing service or operation of any high pressure system. The CAUTIONS and WARNINGS are included in each service manual and with each Accessory Data sheet. CAUTIONS and WARNINGS can also be viewed online at www.catpumps.com/cautions-warnings or can be requested directly from Cat Pumps.

WARRANTY

View the Limited Warranty on-line at www.catpumps.com/warranty.



CAT PUMPS

1681 - 94TH LANE N.E. MINNEAPOLIS, MN 55449-4324
PHONE (763) 780-5440 — FAX (763) 780-2958
e-mail: techsupport@catpumps.com
www.catpumps.com